

DESCRIPTION

The Canyon is an environmentally friendly, American Innova® moulded wood seat, designed for universal pans in Commercial and Residential applications.

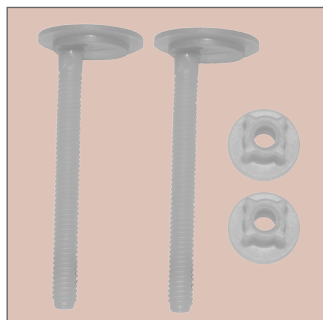

HARDWARE KIT

Plastic Hardware Kit

- Bottom tightening

HINGES

Adjustable Plastic Tuck-Under Hinges

- Adjustable hinges provide a perfect fit by accounting for variances in standard pans
- Stylish tuck-under design minimizes exposure of the hinge

MATERIAL

American Innova®

- High-gloss finish
- Manufactured from a wood flour and thermoset resin mix
- Uses responsibly sourced wood and water-based paints

BUMPERS

- All American Innova® seats come with factory-installed, color-matched bumpers.

APPLICATIONS

- Commercial Use
- Residential Use

PACKAGING & WEIGHTS

Individual Unit

- Individual Seat Weight: 2.9 kg

Individual Packaged Unit

- Packaging: Corrugate Carton
- Packed Seat Weight: 3.15 kg
- Packaging Dimensions: 470 x 375 x 70 mm

Master Carton

- 6 Individual Units
- Weight: 19.55 kg
- Master Carton Dimensions: 435 x 385 x 485 mm

Pallets

- Euro Pallet (80 x 120 cm) Quantities: 144
- Standard Pallet (100 x 120 cm) Quantities: 144

SPECIFICATIONS

- Style: Closed Front, With Cover
- Size/Shape: Universal
- Material: American Innova®
- Hinges: Adjustable Plastic Tuck-Under
- Hardware Kit: Plastic Hardware Kit
- Bumpers: Ring: 2 / Cover: 2
- Suggested Uses: Commercial or Residential

CLEANING

Use warm, soapy water to clean your seat.

MADE IN

This seat is manufactured in the USA and proudly assembled in Great Britain.

AVAILABLE COLOURS

White

DIMENSIONS

