

DESCRIPTION

The Asti CP is a highly stylised, American Innova® environmentally friendly, moulded wood seat, designed for universal pans in Commercial and Residential applications.

This seat features the American Innova Generation XXI material that provides a highly stylised look. It's manufactured from a wood flour and thermoset resin mix. This seat is also made from responsibly sourced wood and is finished with water-based paints making it the perfect environmentally friendly option.

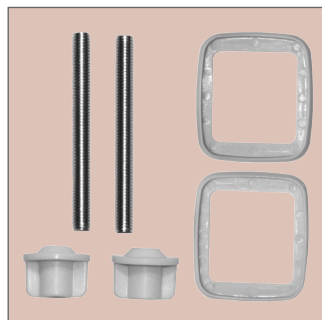

HARDWARE KIT

Standard Hardware Kit

- Threaded stainless steel rod fixes into the base of the hinge
- Nuts have a domed top that helps keep them properly centered when tightening
- Bottom tightening
- Includes a custom-fit gasket to protect the ceramic and to help prevent the seat from slipping

HINGES

Adjustable Chrome Tuck-Under Hinges

- "5 Hole" system provides the perfect combination of adjustability and stability
- Stylish tuck-under design minimizes exposure of the hinge

MATERIAL

American Innova Generation XXI

- Highly stylised design
- Manufactured from a wood flour and thermoset resin mix
- Uses responsibly sourced wood and water-based paints

BUMPERS

- 2 non-slip bumpers on the ring
- 2 non-slip bumpers on the cover

APPLICATIONS

- Commercial Use
- Residential Use

PACKAGING & WEIGHTS

Individual Unit

- Individual Seat Weight: 3.19 kg

Individual Packaged Unit

- Packaging: Corrugate Carton
- Packed Seat Weight: 3.44 kg
- Packaging Dimensions: 470 x 375 x 70 mm

Master Carton

- 6 Individual Units
- Weight: 21.18 kg
- Master Carton Dimensions: 435 x 385 x 485 mm

Pallets

- Euro Pallet (80 x 120 cm) Quantities: 144
- Standard Pallet (100 x 120 cm) Quantities: 144

SPECIFICATIONS

- Style: Closed Front, With Cover
- Size/Shape: Universal
- Material: American Innova Generation XXI
- Hinges: Adjustable Chrome Tuck-Under
- Hardware Kit: Standard Hardware Kit
- Bumpers: Ring: 2 Non-Slip / Cover: 2 Non-Slip
- Suggested Uses: Commercial or Residential

CLEANING

Use warm, soapy water to clean your seat.

MADE IN

This seat is manufactured in the USA and proudly assembled in Great Britain.

AVAILABLE COLOURS

White

DIMENSIONS

